



CB.80...

BASE STYLE LOAD CELLS



- ✓ Compact design
- ✓ Easy installation
- ✓ High reliability
- ✓ No influence of other forces
- ✓ Resultant parallel to the supporting surface
- ✓ High load from 250N to 2000N

A reliable web tension control may reduce web tears in order to increase productivity. CB load cells, used in a precise tension control system, are designed to carry out these delicate tasks.

CB base style load cells offer the ideal solution for detecting web tension because they can measure it without the influence of other forces such as the weight of the roller, the supports,...

The structure of CB load cells allows to eliminate the tare mechanically rather than electrically as with other kinds of load cells. Moreover, they offer high resistance to vibrations and overloads.

CB base style load cells are usually applied on paper mills, supercalandring and rolling machines, but also on plants in which the laminate must be treated with extreme attention.

Operating principle: CB load cells use the strain gauge operating principle to guarantee a perfect detection of the web tension. Strain gauges resistors are mounted on an inner metal foil of a load cell and connected to each other in a "wheatstone bridge" able to convert a mechanical movement into an electrical signal, that must be amplified by suitable amplifiers.

TECHNICAL DRAWING

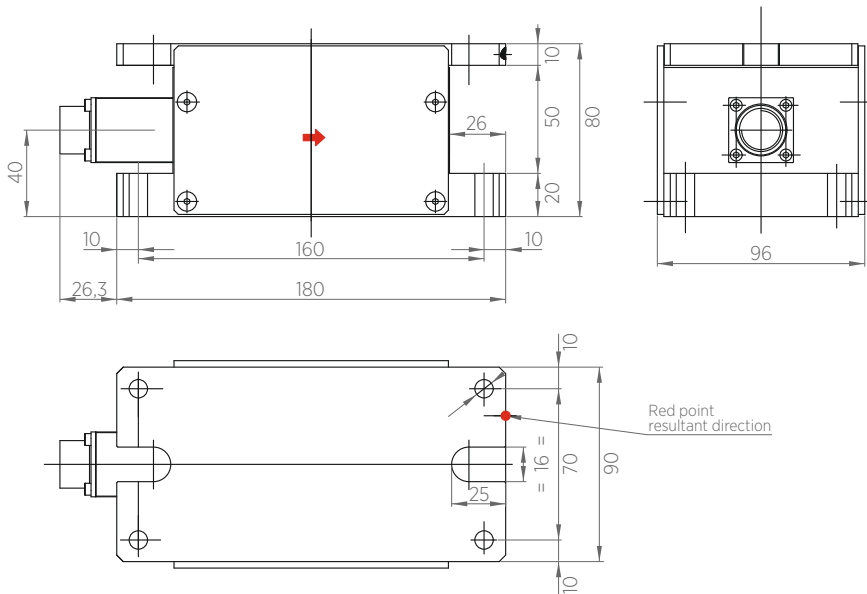

Selection model table

Code	Load N
CB.80.25	250
CB.80.50	500
CB.80.100	1000
CB.80.200	2000

* for other model contact our technical dpt.

CB.80.xx

└─ Load N
└─ Load cell model

TECHNICAL DATA

Precision class		0,5
Sensitivity	Normal Supply	from 1,5mV/V to 2,0mV/V 10V - max 15V
Total error-repeatability-histeresy-linearity		< ± 0,05% end scale value
Measuring principle		strain gauge full bridge
Strain gauge bridge resistance		350Ω Ohm
Max overload		300%
Temperature range		0°C/+60°C
Option		4-20 mA output
Material		aluminium

*Data are subject to technical change without notice



Re S.p.A.
via Firenze 3
20060 Bussero (MI) Italy

T +39 02 9524301
F +39 02 95038986
E info@re-spa.com

Assistenza tecnica
Technical support
T +39 02 952430.300
E support@re-spa.com

Assistenza commerciale
Sales support
T +39 02 952430.200
E sales@re-spa.com